







Installation Instructions Header Windshield Channel

Vehicle Application:

- Jeep JK Wrangler and Wrangler Unlimited
2007 – Current
Part Number: 51243

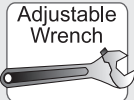
www.Bestop.com - We're here to help! Visit our web site and click on "[Ask a Question](#)". Click here for more [Jeep® Accessories by Bestop](#).

INSTALLATION TIME	SKILL LEVEL		
 3/4 Hour	 2 - Moderately Easy		
TOOLS			
 Flat-Head Screwdriver	 Phillips Screwdriver	 Adjustable Wrench	 Safety Glasses



⚠ WARNING This product is designed primarily to enhance the appearance of the vehicle. Do not rely in any way on the components of this product to protect against injury or death in the event of an accident. Never operate the vehicle in excess of manufacturer's specifications.

WEAR SEAT BELTS AT ALL TIMES

Read and follow, precisely, all installation instructions provided when installing product. Failure to do so may result in a poor fit and could place occupants of the vehicle in a potentially dangerous situation.

Header Windshield Channel Installation Instructions

Parts List and Hardware Identification

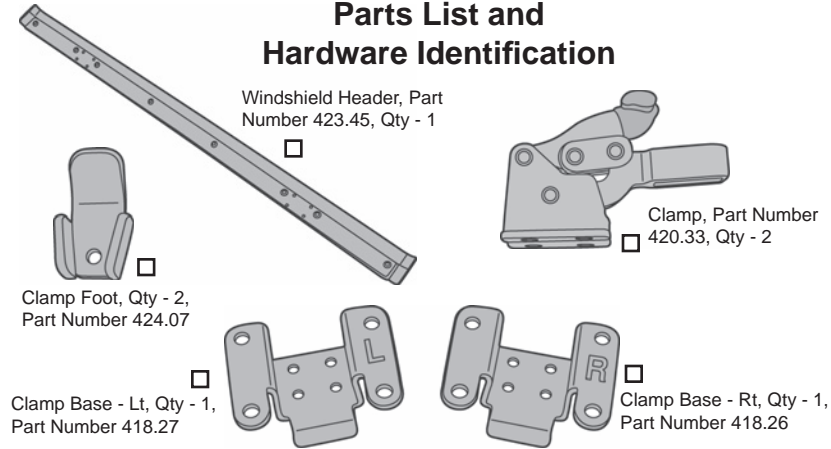

1 Assemble Clamps to Clamp Bases

Place a Clamp on top of a Clamp Base so the clamp lever is positioned over the tab on the base. Secure with four (4) #6-32 x 3/8" Fillister Head Screws and #6-32 Locknuts. Repeat with the other clamp and base.

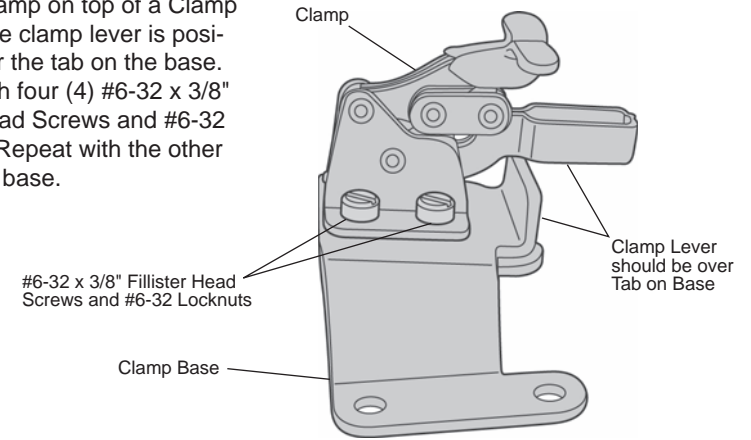

Hardware

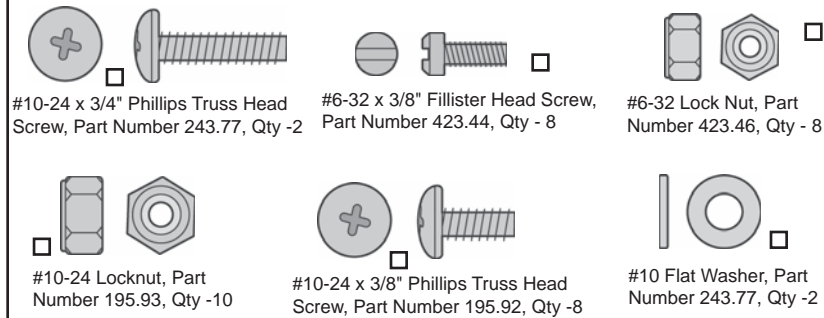

2 Install Clamp Foot to Clamp Lever

Attach a Clamp Foot to each Clamp lever as shown with one (1) #10-24 x 3/4" Phillips Truss Head Screw, one (1) #10 Flat Washer and one (1) #10-24 Locknut. Leave the fasteners loose for later adjustment.

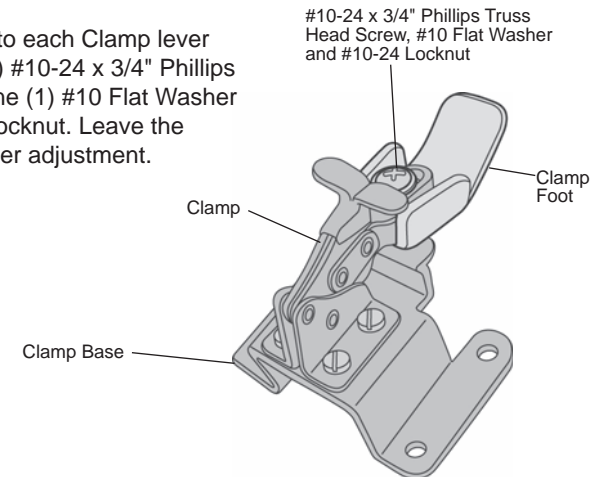

Header Windshield Channel Installation Instructions

3 Attach Clamp Base Assemblies to Windshield Header

The bottom of each Clamp Base is stamped with an R for right or an L for left.

Orient the Windshield Header as shown and position the Right Clamp Base Assembly with the R over the four holes and the lever of the clamp pointing to the front of the Header. Secure the Clamp Base Assembly to the Header with four (4) #10-24 x 3/8" Phillips Truss Head Screws and four (4) #10-24 Locknuts.

Repeat this procedure with the left base.

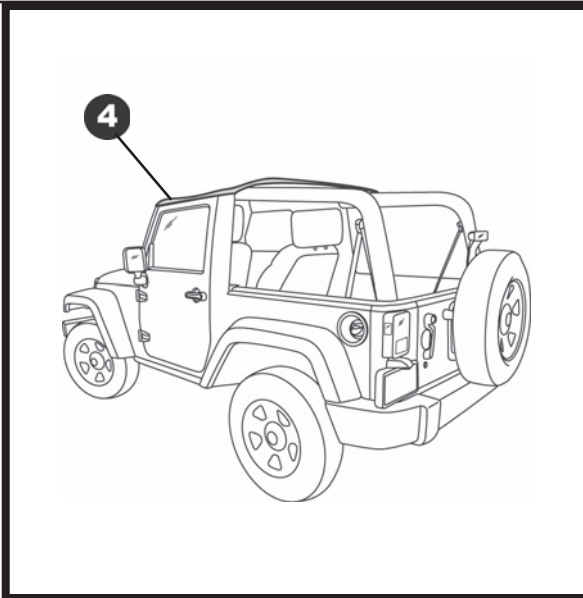
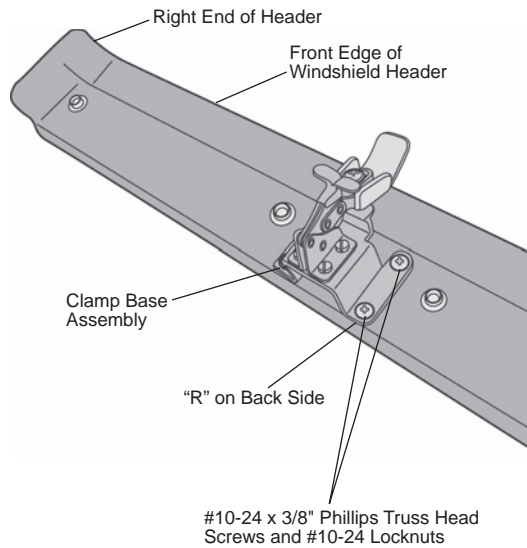

4 Install Windshield Header Assembly on Windshield

Open both clamps and position the Windshield Header Assembly over the windshield. Lower a Clamp Base over the loop on the windshield with the base tab in front of the loop. Close each of the clamps. Push a Clamp Foot forward so it is tight against the windshield and tighten the #10-24 x 3/4" Phillips Truss Head Screws. If the front edge of the header can be lifted off the rubber seal on the windshield, move the foot further forward. If the effort needed to close the clamp is too much, move the clamp toward the rear. Repeat with the other clamp.

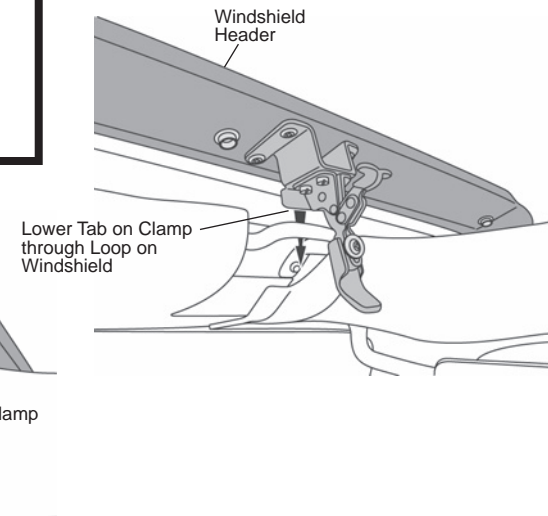

5 Install Bikini

Remove the Windshield Header Assembly from the windshield and attach your bikini as detailed in the bikini instructions.

Header Windshield Channel Installation Instructions

LIMITED WARRANTY

We warrant our product to be free from defects in material and workmanship, for the terms specified below, provided there has been normal use and proper maintenance. This warranty applies to the original purchaser only. All remedies under this warranty are limited to the repair or replacement of any item or items found by the factory to be defective within the time period specified. If you have a warranty claim, first you must call our factory at the number below for instructions. You must retain proof of purchase and submit a copy with any items returned for warranty work. Upon completion of warranty work, if any, we will return the repaired or replaced item or items to you freight prepaid. Damage to our products caused by accidents, fire, vandalism, negligence, misinstallation, misuse, Acts of God, or by defective parts not manufactured by us, is not covered under this warranty.

THE WARRANTY TIME PERIOD IS AS FOLLOWS FOR REPLACE-A-TOP™, SAILCLOTH REPLACE-A-TOP™, SUPERTOP®, SUPERTOP® REPLACEMENT SKINS, SUNRIDER®, AND TIGERTOP®: TWO YEARS FROM DATE OF PURCHASE.

THE WARRANTY TIME PERIOD IS AS FOLLOWS FOR ALL OTHER “SOFT GOODS” MANUFACTURED BY OUR COMPANY (USING PRIMARILY VINYL, PLASTICS, AND/OR FOAM): ONE YEAR FROM DATE OF PURCHASE.

THE WARRANTY TIME PERIOD IS AS FOLLOWS FOR ALL OTHER “HARD GOODS” MANUFACTURED BY OUR COMPANY (USING PRIMARILY METALS, PLASTICS, AND/OR FIBERGLASS): ONE YEAR FROM DATE OF PURCHASE.

ANY IMPLIED WARRANTIES OF MERCHANTABILITY AND/OR FITNESS FOR A PARTICULAR PURPOSE CREATED HEREBY ARE LIMITED IN DURATION TO THE SAME DURATION AND SCOPE AS THE EXPRESS WRITTEN WARRANTY. OUR COMPANY SHALL NOT BE LIABLE FOR ANY INCIDENTAL OR CONSEQUENTIAL DAMAGE.

Some states do not allow limitations on how long an implied warranty lasts, or the exclusion or limitation of incidental or consequential damages, so the above limitations or exclusions may not apply to you. This warranty gives you specific legal rights, and you may also have other rights which vary from state to state.



For further information or request for warranty work, please contact:
Bestop Inc. Customer Service
Toll-Free: (800)845-3567
Main: (303)465-1755
E-mail: csbestop@Bestop.com
Website: www.Bestop.com